



Light Amphibious Warship

Midshipman 1/C Inocencio, Orr, Rehme, Tregenza
 Professor Jaye Falls, Naval Architecture & Marine Engineering



Mission

The vessel will aim at the transport of Marines in the Western Pacific in support of Expeditionary Advanced Based Operations for the US Navy. The vessel will be a lightweight vessel with beach landing and ASUW capabilities.

Background

- Marine transport vessel
- Fills gap in Marine mission requirements
- Roll-on/roll-off cargo carrying ability with stern ramp
- Provides support for Expeditionary Advanced Base Operations
- Designed to operate in Western Pacific

Principal Characteristics

Characteristic	Units	Value
LOA	ft	295
LBP	ft	295
LWL	ft	284
B at DWL	ft	50
T	ft	12
D	ft	25
Installed Hp	Hp	7000
Accommodations	#	120
Endurance	days	25
Range	NM	5000
Cargo Capacity	LT	650
Cargo Type	Trucks, Armored Vehicles	

Ship Drawings & Technical Plots



General Arrangements

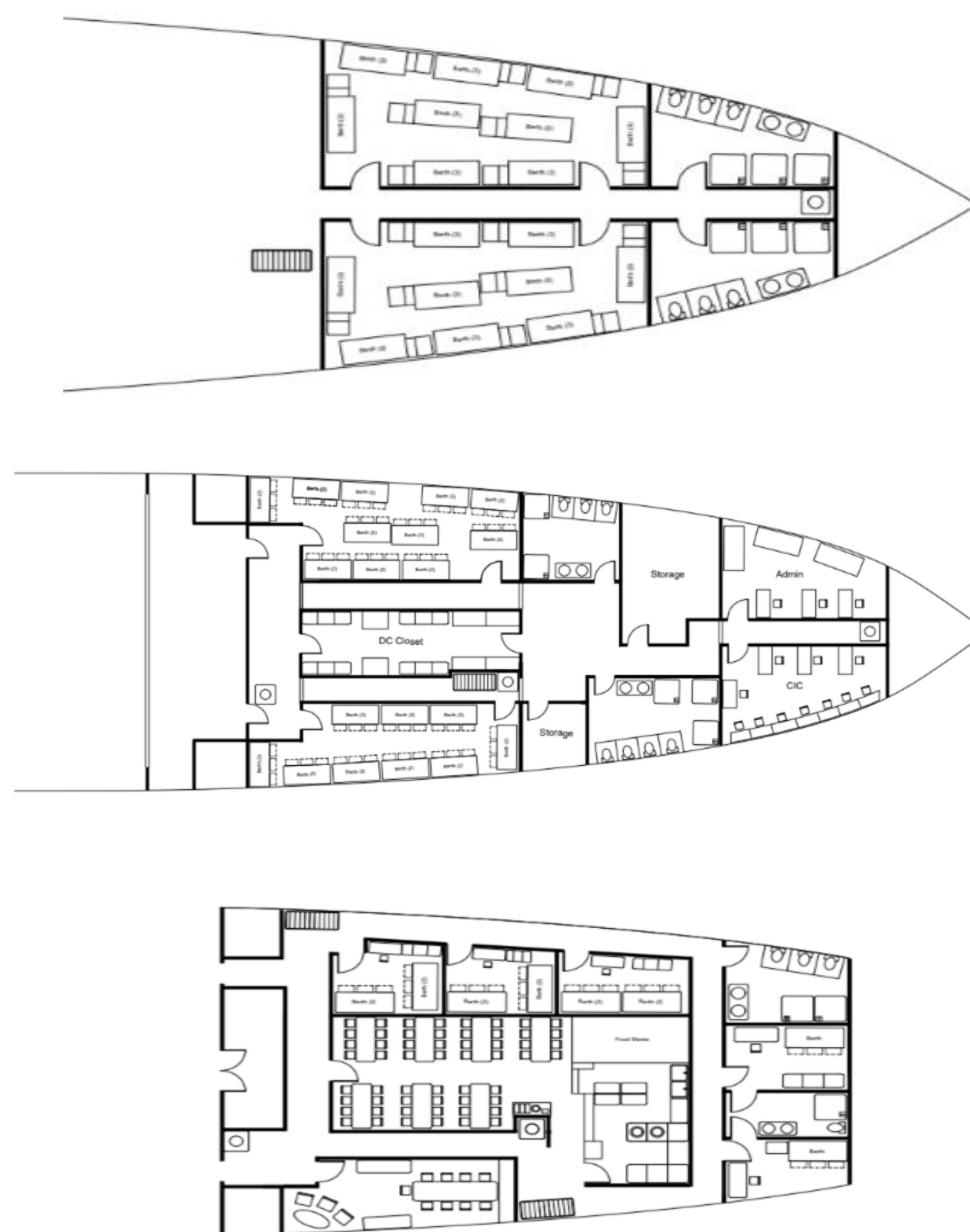

Beaching

- Stern landing
- Reduced draft aft
- Water Jets
- SPJ Schottel Pumpjets

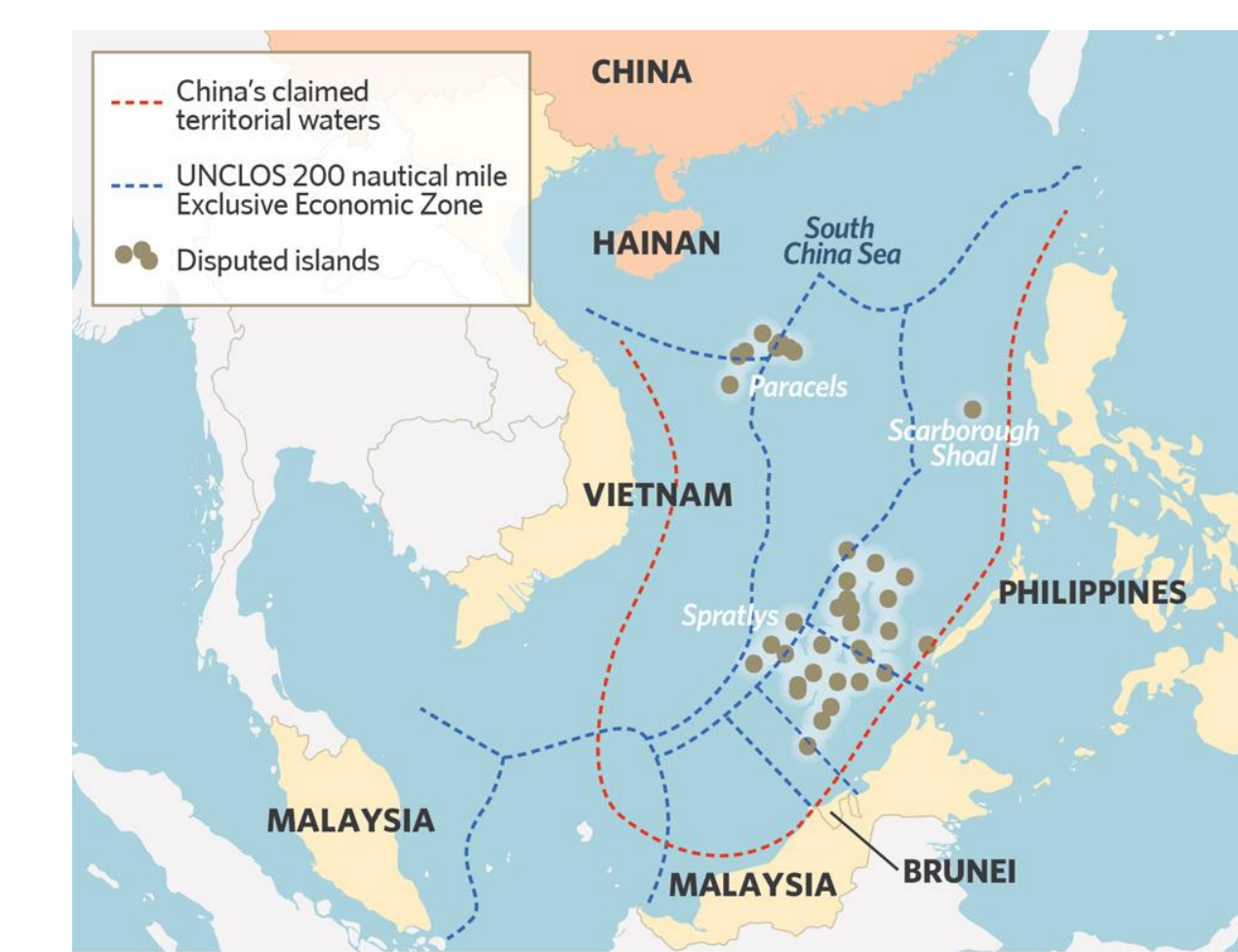

Key Features

- Stern ramp
- Flight Deck
- 10,000 ft² cargo space

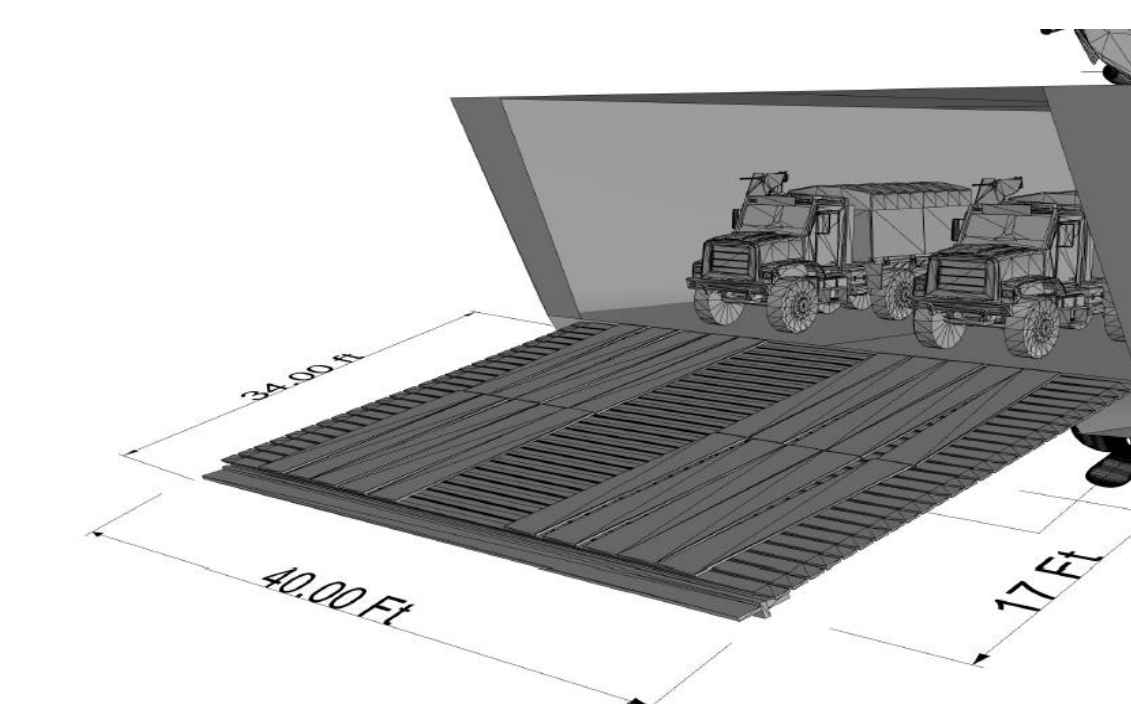

Acknowledgements

- Professor Jaye Falls
- CDR Li Sung, USN
- CDR Paul Magoulick, USN
- CDR Jan Dumm
- Hydrolab Staff
- Fabrication Shop